

Bay & Bow Installation Guide

1. Prior to removing the present window, always check the following **width & height** measurements:
 - Actual bay or bow window frame.
 - Window openings inside the bay or bow frame.
 - Existing window to be replaced.
2. **Remove existing window and interior casings.**
 - Typically install the bay or bow frame into the Rough Opening of the present window. Prep opening by adding additional fasteners to ensure that all wood is secure. If the exterior height dimension is smaller than the interior dimension, it will be necessary to add a 2x Sill to the Sill Plate. Note that the 2x Sill should be ripped to the same dimension as the present Wall Thickness (Jamb Depth). This addition of the new sill should have been determined when the window was measured for ordering purposes.
3. **Cap the new or existing sill** with coil stock and seal the capping with quality caulking (exterior grade silicone) at this time. It will be almost impossible to seal after frame is installed.
4. **Insert the bay/bow frame** into the opening, bringing the interior edge of the frame (head, seat & side jambs) flush with the interior of the wall.
 - Use a straight edge or level to ensure that the bay or bow frame is even on all four sides with the interior wall surface. Insert wood shims as needed to level bay/bow frame in opening. Typically shims will be added to all four sides.
5. **Secure the bay/bow frame** into the opening using a minimum of 3 or 4 hardened steel finish nails per jamb (wood screws may be substituted). Fasten the side jambs first and then the seat and head, always setting the nails into the frame in the same location as your shims. *Using shims on each side of the nail will help protect the hardwood veneer from hammer marks. Complete fastening frame by setting all nails with nail punch. *Nail holes should be filled with wood putty. If using a color stick to fill nail holes, complete this process after the frame is stained.

1- Double check all measurements prior to removing window.



2- Remove present window and casings.



4- Level Bay or Bow Frame in opening



4- Level frame using wood shims



4- Use level or straight edge to ensure frame is even with walls



5- Protect hardwood veneer from hammer marks by using shims on each side of finish nails



6. **Completely insulate**, using fiberglass insulation, around the bay or bow frame and present window jamb.

7. **Install replacement windows** into each opening of the bay/bow frame.

A) All window units must be Wet Glazed (back sealed) against the exterior stops. Apply a heavy bead of high quality sealant (silicone or similar caulking) to the entire perimeter of the interior surface of the exterior stops.

B) Insulate with fiberglass insulation around all replacement window units.

C) Miter interior window stops and install around the complete perimeter of all window units. *Optional Pre-mitered interior window stops are available.

8. **Side Jamb Trim** - 3/4" Cove or Shoe Molding

- Cut 3/4" Cove or Shoe Molding and attach to each side jamb.

9. **Seal Perimeter of Frame** with quality caulking.

10. **Interior Casings - Optional Pre-mitered!**

3-1/2" or 2-1/4" Colonial Casing -

A) Measure and cut (miter) the 3-1/2" interior casing; beginning with the Bottom Face Board. *If the frame does not include Edge Banding, the casings must be installed flush with interior surface of the seat & side jambs.

Edge Banding Option finishes the front edge of the plywood and allows casings to be installed with a reveal. Pre-mitered casings

B) Fasten the Bottom Casing to the seat and wall using finish air nailer. * If hand nailing, pre-drill the casing.

C) Measure and cut both pieces of casing for the sides, match the miters with the bottom casing and fasten to the side jamb.

D) Measure, cut and fasten the top casing.

6" Colonial Stacked Casing -

- This is a two-part system consisting of 6" wide bottom face boards and 2-1/4" colonial casing. * **We recommend ordering this trim Pre-cut and Mitered.**

E) **Installing 6" Face Boards** - The **Bottom Face Board is always installed first.** Measure and mark the Center Point of both the Bottom Face Board and the Seat of the bay/bow window frame. Match the Center Point of the Bottom Face Board with the Center of the frame seat

6- Insulate around frame



7-a: Back Seal Window Stops



7- Install all Window Units



7-b: Insulate between Windows and Frame



7-c: Install Interior Window Stops



8- Install 3/4" Cove Side Jamb Trim

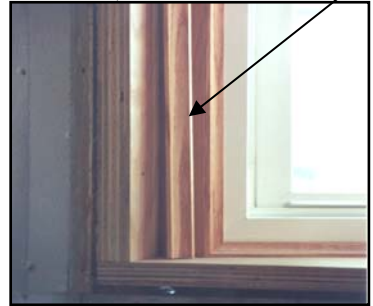

Note: 3-1/2" Colonial Casing is available Pre-mitered. If ordered Pre-mitered the side pieces will be cut 1/4" short, thus dropping the top piece down past the head by 1/4" and creating a perfect sight line.

10-e: Measure and Mark Center of Frame and Bottom Face Board



- F) **Fasten the Bottom Face Board** by beginning at one end and working your way over to the other end, **making sure that the face board is flush with the top surface of the frame seat.**
- G) **Install Side Face Boards**, by placing the side boards on top of the bottom board making sure that the two are aligned square (butt joint). Starting at the bottom, fasten the side board to the jamb and wall, working your way to the top making sure that the side board is Flush with the interior surface of the side jamb. **Note - Cut the Side Face Boards 1/4" short**, thus the top face board will be 1/4" lower than the frame head, resulting in a perfect sight line!
- H) **Install Top Face Board**, by placing the top board on top of the two side boards and fasten. Make sure that the ends line up with the outside edge of the side boards. **Note - The Top Face Board will not be flush with the interior surface of the frame head.**
- I) **Install 2-1/4" Colonial Casing** around the outside perimeter of the face boards. **Fasten to the bottom first**, then the sides and top, always starting at the end and working your way to the other end making sure that the outside edge of the 2-1/4" casing is flush with the outside edge of the 6" face board.
- Set nails and putty all holes.**
Lightly Sand all interior wood.

10-f: Match center lines and fasten



10-g: Sides are pre-cut 1/4" short!



10-h: Top Face Board rests on Sides



10-i: Fasten 2-1/4" casing to perimeter



Lightly Sand all Interior Wood Surfaces



Complete Exterior of Bay/Bow Window

11. **Finishing the Top of the Bay/Bow Window - To help minimize the possibility of water leaks from the top of the window, we recommend installing a waterproof barrier over the entire top of the frame (Peal & Seal).**

12. Adjustable Cable Support System -

- **Bay/Bow Windows must be supported**, using either an External Knee Brace or the Cabled Hanging System.
- **Cabled Support Kit includes -** two adjustable turnbuckles, two 24" lengths of steel cable and two lag eyebolts.
- **Fasten Eye Bolts to the structure**, either the header or the overhang. The turnbuckles & cable connect the eye bolts in the bay/bow frame to the eyebolts in the structure. **(See Diagram)**

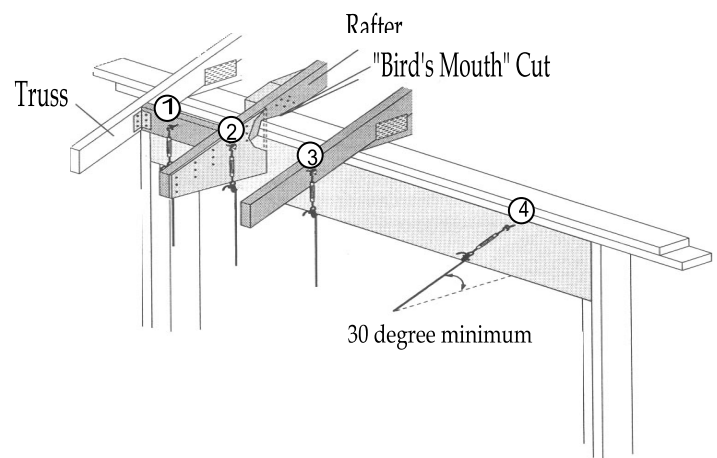

1. Truss tails not located vertically above the lower eyebolt should have a header installed between them and secured with joist hangers. The Top Eyebolt should be anchored to this header.
2. "Birds-mouth" cut rafters should always be reinforced if being used to support the bay or bow window. Attach a piece of 3/4" plywood to fit over the rafter. The Top Eyebolt can now be anchored to the rafter through the plywood (Gusset).
3. Truss tails located vertically above the eyebolt should provide adequate support.
4. The header or top plate should be used to anchor the top eyebolt on installations without an overhang. The angle on the support should not be less than 30 degrees.

A) Fascia Extension – No Roof Application

If the distance between the top of bay/bow frame and the house overhang (soffit) is less than 12", and the frame does not project out past the overhang; this space should be filled with wood (1x4, 1x6, etc). Remove soffit covering material that may be installed over wood overhang; add wood ledger to nail top of Fascia Extension. **Install Adjustable Cable Support System at this time (See Support System Instructions).** Insulate space with fiberglass insulation. Nail the appropriate size wood up on the front of the bay or bow window; nail approximately 1" down from top. Cap the exposed wood in coil stock to match the window, seal any crack areas with quality caulking and re-install the soffit material up to the new fascia extension.

B) Pre-fabricated Hip Style Roof –

- **Set the roof on top of the window;** making sure that it is centered properly. **Trace** the backside against the house wall and remove the roof. Cut the siding away from the house along the trace line and install **J-Channel** over the cut edge. **Tuck Step Flashing and Wall Flashing** under the J-Channel. **Set the roof on top of the window** and remove each of the top panels by backing out the wood screws. Attach the roof to the Bay/Bow Window using 1-5/8" wood screws. Attach the roof to the house wall using 3" wood screws, making sure the screws drive into studs or header. **Install Adjustable Cable Support System –** Drill and Screw **Upper Eye Bolts** through the back panel of roof and into the **header or top plate**. Connect **Turnbuckles** and **Cable** from the **Lower Eye Bolts** mounted in the top of the frame to the **Upper Eye Bolts**. Tighten the Turnbuckles and adjust as necessary to make sure Bay/Bow projection is level. **Insulate the Roof Cavity** with fiberglass insulation and re-install the roof top panels. **Cover the Front Edge & Return with coil.** Apply felt paper or ice and water barrier to top panels and install desired roofing shingles; making sure to utilize new step flashing at each course, or install metal clad kit (See Clad Kit Instructions).

- 13. Insulate Exterior Projection of Bay/Bow Seat -** If you have ordered the frame without one of our Pre-insulated Seat Options, insulate seat now. Cut 1" polystyrene foam sheet to fit bottom base of bay/bow. Fasten to base and clad with coil to match frame.

- 14. Cap and Caulk all exposed Window Casings as needed.**

- 15. Caulk the exterior of all window units to the exterior bay/bow window stops. We recommend using the highest quality caulking available. If using a Silicone product, make sure that it is designed to adhere to vinyl.**



Seal Exterior of Window Units to Frame Window Stops

- 16. Remove any excess caulking and clean the entire exterior of the unit as needed.**

Trace back-side edge of roof



Cut and Remove Siding behind Roof



Position Roof Centered on Frame



Install J-Channel over siding edge



Fasten Roof to Wall and Frame



Anchor Upper Eyebolts through Roof



Complete Turn Buckle Hanging System



Insulate all Roof Cavities

